



CATEGORY

LINE
SUPPLIES

AMMO ITEM #

6V4AH

Company: _____

Job: _____ #Item: _____

Notes: _____

Sealed Lead Acid Battery



FEATURES

- Absorbent Glass Mat(AGM) technology for efficient gas recombination of up to 99% and freedom from electrolyte maintenance or water adding
- Not restricted for air transport-complies with IATA/ICAO Special Provision A67
- UL-recognized component
- Can be mounted in any orientation
- Computer designed lead, calcium tin alloy grid for high power density
- Long service life, float or cyclic applications
- Maintenance-free operation
- Low self discharge

SPECIFICATION

- Nominal voltage: _____ 6V
- Number of cells: _____ 3
- Design life: _____ 5 years
- Length: _____ 2.76 in
- Width: _____ 1.85 in
- Height: _____ 3.98 in
- Total Height: _____ 4.21 in

BATTERY CONSTRUCTION

- Component: _____ Raw material
- Positive plate: _____ Lead dioxide
- Negative plate: _____ Lead
- Container: _____ ABS
- Cover: _____ ABS
- Safety valve: _____ Rubber
- Terminal: _____ Copper
- Separator: _____ Fiberglass
- Electrolyte: _____ Sulfuric acid



LINE SUPPLIES



400 MARTIN LUTHER KING JR WAY, BRIDGETON, NJ 08302
 PHONE : (718).338.1851 FAX : (718).228.1851
 orders@ammoelectric.com

www.ammoelectric.com



CATEGORY

LINE
SUPPLIES

AMMO ITEM #

6V4AH

Sealed Lead Acid Battery



PERFORMANCE CHARACTERISTICS		
CAPACITY 77°F (25°C)	20 hour rate (0.2A, 5.25V)	4.0Ah
	INTERNAL RESISTANCE	Full charged Battery 77°F (25°C) 35mΩ
CAPACITY AFFECTED BY TEMPERATURE (20 hours rate)	104°F (40°C)	102%
	77°F (25°C)	100%
	32°F (10°C)	85%
	5°F (-15°C)	65%
SELF-DISCHARGE 68°F (20°C)	Capacity after 3 month storage	90%
	Capacity after 6 month storage	80%
	Capacity after 12month storage	60%
MAX. DISCHARGE CURRENT 77°F (25°C)		60 A (5 S)
CHARGE (Constant Voltage)	Float: 6.80~6.90V/ 77°F/ (25°C)	
	Cycle: 7.25~7.45V/ 77°F/ (25°C)	
	Max. Current: 1A	

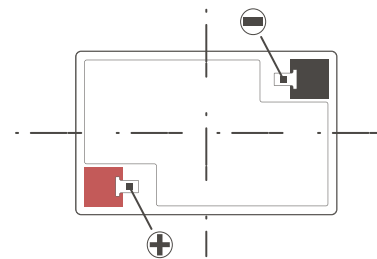
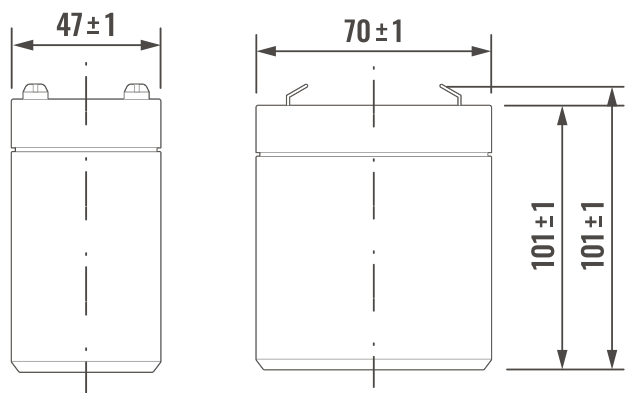

MEASURES in mm

TERMINAL F1

PACKAGING

- Approx. Weight: _____ 680 g
- PKG: _____ 20
- UPC number: _____ 837654089651

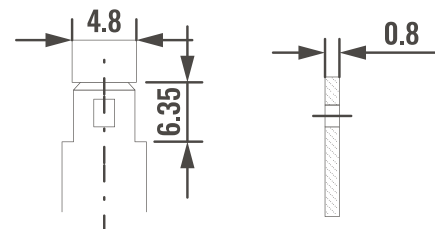

LINE SUPPLIES



400 MARTIN LUTHER KING JR WAY, BRIDGETON, NJ 08302
 PHONE : (718).338.1851 FAX : (718).228.1851
 orders@ammoelectric.com

www.ammoelectric.com