



CATEGORY
**ELECTRICAL
 BOXES**

AMMO ITEM #

AR271

Company: _____
 Job: _____ #Item: _____
 Notes: _____

4" Octagon Concrete Rings 2-1/2" Deep



APPLICATIONS

- Concrete rings are used with poured deck (floor) in highrise construction
- These boxes are installed on wooden or steel concrete forms
- After the forms are removed, the box is flush with the concrete

PRODUCT FEATURES

- Flat sides provide excellent contact for locknuts
- External ears are used to nail the ring to the wood form
- Top cover is removable for before-pour work
- Ears on inside of box are for fixtures
- Waxed fixture ears prevent concrete from interfering with the threads
- A variety of covers are available
- Material: Steel

GENERAL PRODUCTIN FORMATION

Wiring System: Conduit

RECOMMENDED MAX LOAD

- Ceiling Fan (Dynamic) Lbs.: _____ No
- Fixture (Static) Lbs.: _____ 50

CONFIGURATION

- Drawn or Welded: _____ Welded
- Side Knockout(s): _____ Single Row KO' s of 1/2 in. and 3/4 in.

PRODUCT MEASUREMENTS

- Depth: _____ 2-1/2 in.
- Cubic Inches: _____ 0.654
- Wt. Ea. (Lbs.): _____ 24.5
- Product Length (in.): _____ 2.50
- Product Width (in.): _____ 4.00
- Product Height (in.): _____ 4.00

PACKAGING

- PKG: _____ 25
- UPC Number: _____ 837654066614

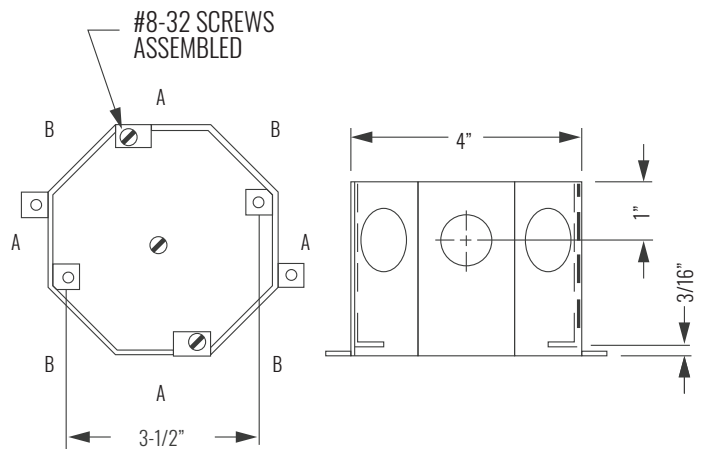

ELECTRICAL BOXES & COVERS



400 MARTIN LUTHER KING JR WAY, BRIDGETON, NJ 08302
 PHONE : (718).338.1851 FAX : (718).228.1851
 orders@ammoelectric.com

www.ammoelectric.com