



CATEGORY

WEATHERPROOF

AMMO ITEM #

AR2C-2G

Company: \_\_\_\_\_

Job: \_\_\_\_\_ #Item: \_\_\_\_\_

Notes: \_\_\_\_\_

# Weatherproof Box Covers



## APPLICATION

Covers for cast metal flush device boxes suitable for use in wet locations

## FEATURES

- Two GFCI
- Include gasket and screw

## MATERIAL

- Cover plate: die cast zinc
- Cover: die cast zinc
- Spring: formed spring steel

## FINISH

Gray

## DIMENSIONS

- A: \_\_\_\_\_ 4.54 in
- B: \_\_\_\_\_ 4.54 in

## CERTIFICATION

UL Standard: 514A

## PACKAGING

- Weight: \_\_\_\_\_ 267 g
- PKG: \_\_\_\_\_ 50
- UPC Number: \_\_\_\_\_ 837654069554

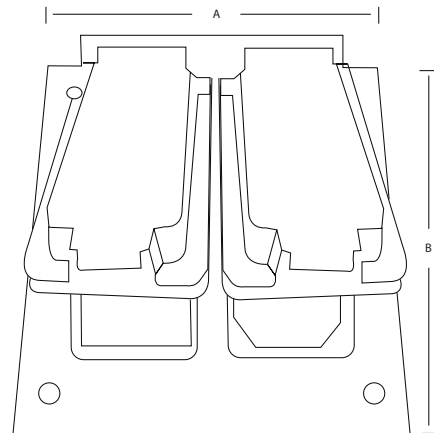

WEATHERPROOF



400 MARTIN LUTHER KING JR WAY, BRIDGETON, NJ 08302  
PHONE : (718).338.1851 FAX : (718).228.1851  
orders@ammoelectric.com

www.ammoelectric.com