



CATEGORY  
**ELECTRICAL  
FITTINGS**

AMMO ITEM #

**ARCCNS-300**

Company: \_\_\_\_\_  
Job: \_\_\_\_\_ #Item: \_\_\_\_\_  
Notes: \_\_\_\_\_

# EMT Compression Connector



### FEATURES

- Compression type connector
- Concrete tight
- Assembled with a steel locknut
- Available with insulated throat

### MATERIAL

Steel with Zinc Plated

### MEASUREMENTS

- Depth: \_\_\_\_\_ 3 in
- A: \_\_\_\_\_ 3.94 in
- B: \_\_\_\_\_ 4.13 in
- C: \_\_\_\_\_ 0.87 in

### PACKAGING

- Weight: \_\_\_\_\_ 858 g
- PKG: \_\_\_\_\_ 6
- UPC Number: \_\_\_\_\_ 837654088227

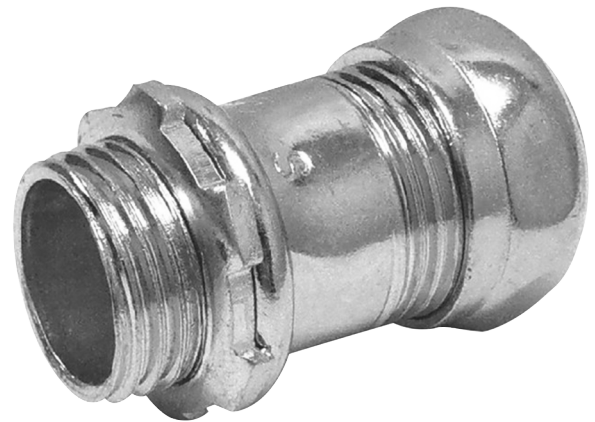
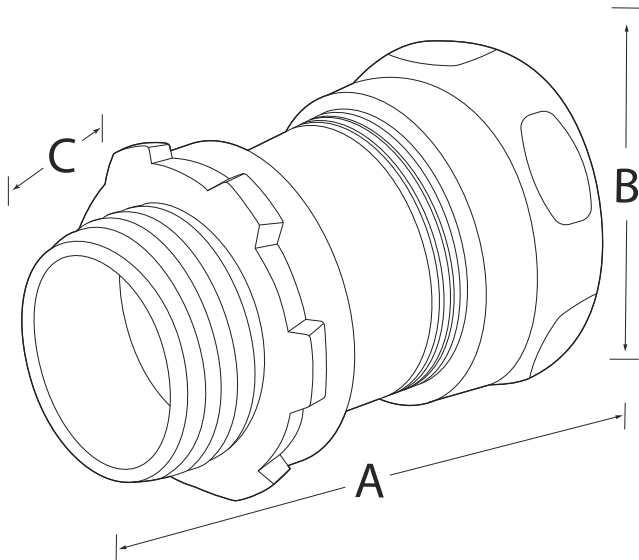

## ELECTRICAL FITTINGS



400 MARTIN LUTHER KING JR WAY, BRIDGETON, NJ 08302  
PHONE : (718).338.1851 FAX : (718).228.1851  
orders@ammoelectric.com

[www.ammoelectric.com](http://www.ammoelectric.com)