



CATEGORY  
**ELECTRICAL  
FITTINGS**

AMMO ITEM #

**ARECSM-HDG**

Company: \_\_\_\_\_  
Job: \_\_\_\_\_ #Item: \_\_\_\_\_  
Notes: \_\_\_\_\_

# Edge Type Conduit Support



## APPLICATION

Beam edge conduit clamps are used to mount EMT or rigid conduit perpendicular to beam, channel and angle supports

## MATERIAL

Hot dip galvanized

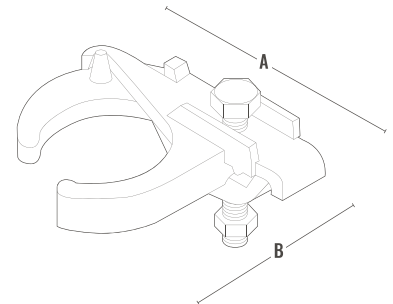

AMMO#	SIZE	A (in)	B (in)	WEIGHT (g)	PKG	UPC
ARECSM-50HDG	1/2"	2.823	2.146	376	50	837654111642
ARECSM-75HDG	3/4"	3.000	2.295	383	50	837654111659
ARECSM-100HDG	1"	3.201	2.618	450	50	837654111666
ARECSM-125HDG	1-1/4"	3.374	2.961	504	25	837654111673
ARECSM-150HDG	1-1/2"	3.535	3.264	547	25	837654111680
ARECSM-200HDG	2"	4.094	3.969	876	25	837654111697
ARECSM-250HDG	2-1/2"	4.370	4.409	1061	10	837654111703
ARECSM-300HDG	3"	4.882	5.236	1232	10	837654111710

## ELECTRICAL FITTINGS



400 MARTIN LUTHER KING JR WAY, BRIDGETON, NJ 08302  
PHONE : (718).338.1851 FAX : (718).228.1851  
orders@ammoelectric.com

www.ammoelectric.com