



CATEGORY
**ELECTRICAL
 FITTINGS**
 AMMO ITEM #
ARECSM-MI

Company: _____
 Job: _____ #Item: _____
 Notes: _____

Edge Type Conduit Support



APPLICATION

- The Malleable Iron construction is capable of supporting heavy loads and ensuring mechanical protection
- Trade size from 1/2" to 3"

FEATURES

- Malleable iron construction ensures mechanical protection for the raceway
- Zinc Electroplated for added corrosion protection

MATERIAL

- Malleable iron

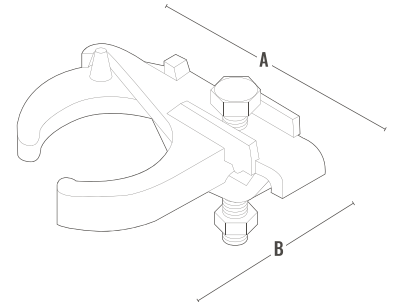

AMMO#	SIZE	A (in)	B (in)	WEIGHT (g)	PKG	UPC
ARECSM-50MI	1/2"	2.823	2.146	376	50	837654118016
ARECSM-75MI	3/4"	3.000	2.295	383	50	837654118023
ARECSM-100MI	1"	3.201	2.618	450	50	837654118030
ARECSM-125MI	1-1/4"	3.374	2.961	504	25	837654118047
ARECSM-150MI	1-1/2"	3.535	3.264	547	25	837654118054
ARECSM-200MI	2"	4.094	3.969	876	25	837654118061
ARECSM-250MI	2-1/2"	4.370	4.409	1061	10	837654118078
ARECSM-300MI	3"	4.882	5.236	1232	10	837654118085

ELECTRICAL FITTINGS



400 MARTIN LUTHER KING JR WAY, BRIDGETON, NJ 08302
 PHONE : (718).338.1851 FAX : (718).228.1851
 orders@ammoelectric.com

www.ammoelectric.com