



CATEGORY

NEC (Nipples,  
Elbows & Couplings)

AMMO ITEM #

AREMT-30

Company: \_\_\_\_\_

Job: \_\_\_\_\_ #Item: \_\_\_\_\_

Notes: \_\_\_\_\_

# EMT 30° Elbow Galvanized



| AMMO#       | SIZE   | A<br>(in) | B<br>(in) | C<br>(in) | OD<br>(in)  | THICKNESS T<br>(in) +/- | STRAIGHT<br>LENGTH L | RADIUS<br>R (in) | WEIGHT<br>(g) | PKG | UPC          |
|-------------|--------|-----------|-----------|-----------|-------------|-------------------------|----------------------|------------------|---------------|-----|--------------|
| AREMT-12530 | 1-1/4" | 8.325     | 2.23      | 8.619     | 1.510±0.005 | 0.063                   | 2.721                | 7.25             | 394           | 30  | 837654086483 |
| AREMT-15030 | 1-1/2" | 9.604     | 2.573     | 9.942     | 1.740±0.005 | 0.063                   | 3.169                | 8.25             | 499           | 15  | 837654086490 |
| AREMT-20030 | 2"     | 10.59     | 2.837     | 10.964    | 2.197±0.005 | 0.063                   | 3.424                | 9.5              | 758           | 10  | 837654086506 |
| AREMT-25030 | 2-1/2" | 14.007    | 3.753     | 14.501    | 2.875±0.010 | 0.072                   | 5.078                | 10.5             | 1285          | 50  | 837654086513 |
| AREMT-30030 | 3"     | 16.351    | 4.381     | 16.928    | 3.500±0.015 | 0.072                   | 5.748                | 13               | 1774          | 35  | 837654086520 |
| AREMT-35030 | 3-1/2" | 17.666    | 4.734     | 18.289    | 4.000±0.020 | 0.083                   | 5.984                | 15               | 2696          | 35  | 837654086537 |
| AREMT-40030 | 4"     | 20.096    | 5.385     | 20.805    | 4.500±0.020 | 0.083                   | 7.085                | 16               | 3349          | 35  | 837654086544 |

## EASY AND ACCURATE BENDING

Processed by high frequency induction welding to prevent cracking when bend

## EASY WIRE PUSHING AND PULLING

Grey color epoxy resin coating with inside welding removed

## HIGH CORROSION RESISTANCE

Pure zinc coating on the exterior wall with clear anti-corrosion coating finish

## STANDARDS

It complies with UL797/ANSI C80.3 standards

## MATERIALS

- Hot dipped Galvanized
- Galv In-line

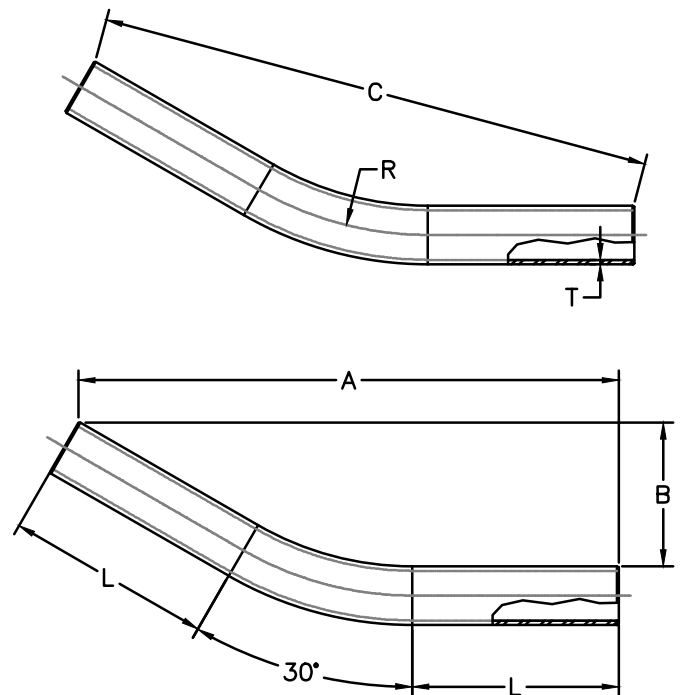
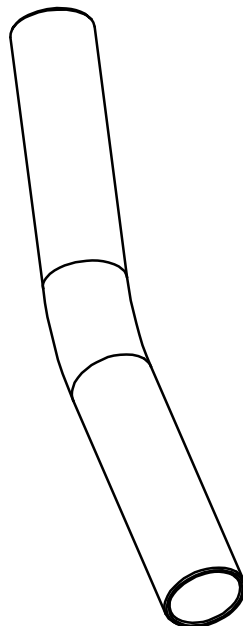

## NEC (Nipples, Elbows & Couplings)



400 MARTIN LUTHER KING JR WAY, BRIDGETON, NJ 08302  
PHONE : (718).338.1851 FAX : (718).228.1851  
orders@ammoelectric.com

www.ammoelectric.com