



CATEGORY

NEC (Nipples,  
Elbows & Couplings)

AMMO ITEM #

AREMT-90

Company: \_\_\_\_\_

Job: \_\_\_\_\_ #Item: \_\_\_\_\_

Notes: \_\_\_\_\_

## EMT 90° Elbow Galvanized Steel

**• Easy and accurate bending**

Processed by high frequency induction welding to prevent cracking when bend

**• Easy wire pushing and pulling**

Inside welding removed, and with the grey color epoxy resin coating

**• High corrosion resistance**

Pure zinc coating on the exterior wall with clear anti-corrosion coating finish

**• Standards**

It complies with UL797/ANSI C80.3 standards

EMT galvanizing process for greater protection against corrosion. Finished with durable and clear anti-corrosion coating for higher protection outside and higher grade epoxy coating inside

Elbows are used to connect the EMT conduit and change the path. Sizes from 1/2" to 4"

Available in standard sizes 90°, 60°, 45°, 30°, 22.5° bends

AMMO#	SIZE	MIN RADIUS R (in)	OFFSET C (in)	STARIGHT END D (in)	WEIGHT (g)	PKG	UPC
AREMT-5090	1/2"	4	6.96	2.5	111	50	837654064436
AREMT-7590	3/4"	4.5	7.73	2.5	200	50	837654064443
AREMT-10090	1"	5.75	9.36	3	351	25	837654064450
AREMT-12590	1-1/4"	7.25	11.38	3.25	646	20	837654064467
AREMT-15090	1-1/2"	8.25	12.76	3.5	842	20	837654064474
AREMT-20090	2"	9.5	15.01	4.25	1232	10	837654064481
AREMT-25090	2-1/2"	10.5	17.11	5	2185	1	837654064498
AREMT-30090	3"	13	20.33	5.5	3133	1	837654064504
AREMT-35090	3-1/2"	15	23.38	6.25	4772	1	837654064511
AREMT-40090	4"	16	25.4	7	5843	1	837654064528

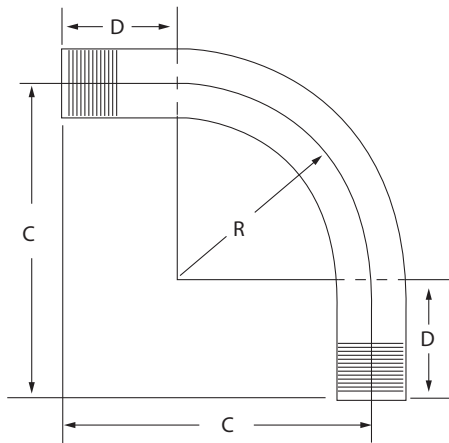

### NEC (Nipples, Elbows & Couplings)

400 MARTIN LUTHER KING JR WAY, BRIDGETON, NJ 08302  
PHONE : (718).338.1851 FAX : (718).228.1851  
orders@ammoelectric.com

www.ammoelectric.com