



CATEGORY

**NEC (Nipples,
Elbows & Couplings)**

AMMO ITEM #

**EMT 22.5°
Elbow**

Company: _____

Job: _____ #Item: _____

Notes: _____

EMT 22.5° Elbow Galvanized



AMMO#	SIZE	A (in)	B (in)	C (in)	OD (in)	THICKNESS T 10% (in)	STRAIGHT LENGTH L (in)	RADIUS R (in)	WEIGHT (g)	PKG	UPC
AREMT-12522	1-1/4"	7.720	1.536	7.872	1.510±0.005	0.063	2.721	7.250	358	30	837654086384
AREMT-15022	1-1/2"	8.921	1.774	9.096	1.740±0.005	0.063	3.169	8.250	451	15	837654086391
AREMT-20022	2"	9.802	1.950	9.994	2.197±0.005	0.063	3.424	9.500	689	10	837654086407
AREMT-25022	2-1/2"	13.237	2.633	13.497	2.875±0.010	0.072	5.078	10.500	1172	50	837654086414
AREMT-30022	3"	15.364	3.056	15.665	3.500±0.015	0.072	5.748	13.000	1604	35	837654086421
AREMT-35022	3-1/2"	16.488	3.280	16.811	4.000±0.020	0.083	5.984	15.000	2436	35	837654086438
AREMT-40022	4"	18.893	3.758	19.263	4.500±0.020	0.083	7.085	16.000	3038	35	837654086445

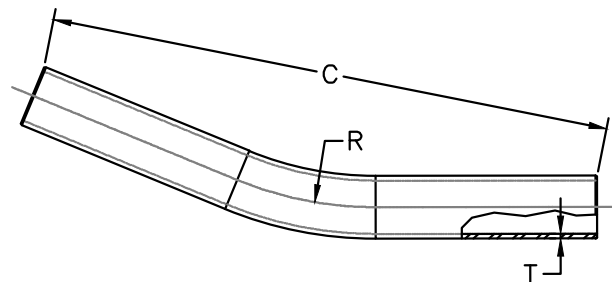
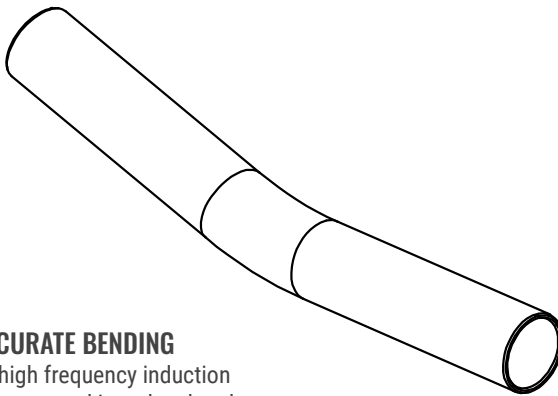

EASY AND ACCURATE BENDING

Processed by high frequency induction welding to prevent cracking when bend

EASY WIRE PUSHING AND PULLING

Grey color epoxy resin coating with inside welding removed

HIGH CORROSION RESISTANCE

Pure zinc coating on the exterior wall with clear anti-corrosion coating finish

MATERIALS

- Hot dipped Galvanized
- Galv In-line

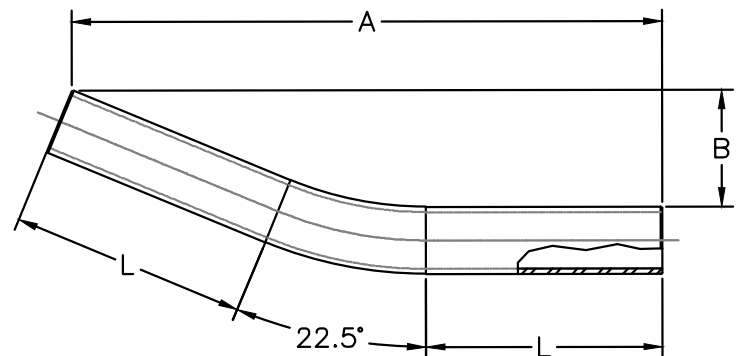

NEC (Nipples, Elbows & Couplings)



400 MARTIN LUTHER KING JR WAY, BRIDGETON, NJ 08302
PHONE : (718).338.1851 FAX : (718).228.1851
orders@ammoelectric.com

www.ammoelectric.com