



CATEGORY
**ELECTRICAL
FITTINGS**

AMMO ITEM #

ARMP4S-SB

Company: _____

Job: _____ #Item: _____

Notes: _____



Cable Ties Mounts Pads Screw

APPLICATIONS

- For safe organization of cables
- Wrap the Cable and fix with mounts pad

FEATURES

- Natural: polyamide 6.6 natural + Adhesive Tape
- Black: polyamide 6.6 natural+ ~1% carbon black + Adhesive Tape
- Flammability of raw material : UL 94 - V2
- Humidity absorption: 2,7% - 2,8% (23° C - 50% R.H.)
- Installation temperature: -10° C
- Working temperature: -10° C ~ +50° C
- Max sustainable temperature for short time: +85°C
- Good resistance to bases, oils, greases, oil derivates, chloride solvents. Limited resistance to acids. Not resistant to phenols
- Carbon black addition gives a better UV resistance

MATERIAL

Nylon PA66

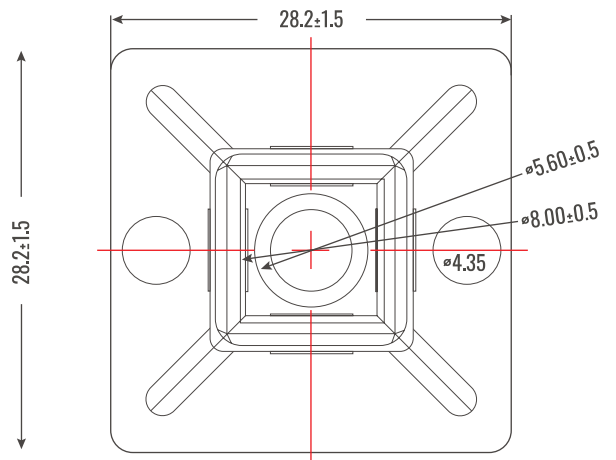

AMMO#	SIZE	COLOR	WEIGHT (g)	PKG	UPC
ARMP4S	28x28mm	White	1.59	100	837654113769
ARMP4SB	28x28mm	Black	1.59	100	837654113776

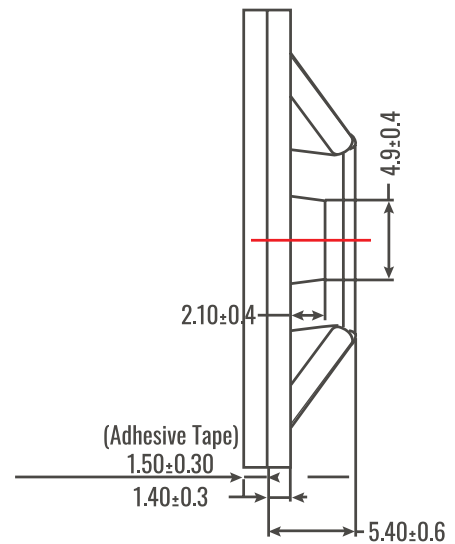
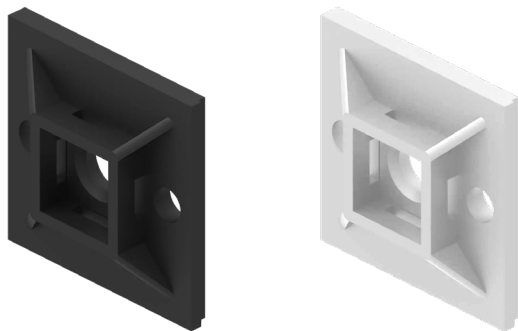

ELECTRICAL FITTINGS



400 MARTIN LUTHER KING JR WAY, BRIDGETON, NJ 08302
PHONE : (718).338.1851 FAX : (718).228.1851
orders@ammoelectric.com

www.ammoelectric.com