



CATEGORY  
**LIGHTING &  
ACCESSORIES**

AMMO ITEM #

**TLS/100**

Company: \_\_\_\_\_

Job: \_\_\_\_\_ #Item: \_\_\_\_\_

Notes: \_\_\_\_\_

# Temporary Lighting String



## POWER CORD STRUCTURAL SIZE STANDARDS

- Number of conductor cores thickness: \_\_ 14AWGx2C
- External protection nominal thickness: \_\_ 0.76 mm
- Minimal external protection thickness: \_\_ 0.61 mm
- Insulation nominal thickness: \_\_\_\_\_ 0.76 mm
- Minimum insulation thickness: \_\_\_\_\_ 0.69
- At 20°C, the conductor is at its maximum: 8.88 Ω/km

## LAMP HOLDERS

- Model: \_\_\_\_\_ UL Certified
- Rating: \_\_\_\_\_ 660W / 600V

## PLUG / TAIL PLUG

- Rating: \_\_\_\_\_ 15A / 125V
- Conductor material: \_\_\_\_\_ Brass

## MATERIAL

PVC / Cooper

## PACKAGING

- PKG: \_\_\_\_\_ 1
- Length: \_\_\_\_\_ 100 FT
- Weight: \_\_\_\_\_ 5400 g
- UPC Number: \_\_\_\_\_ 837654061992

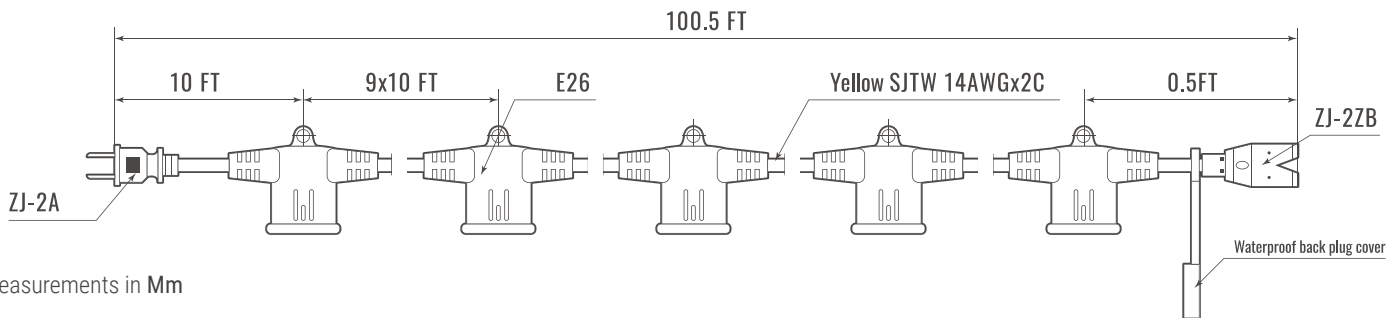
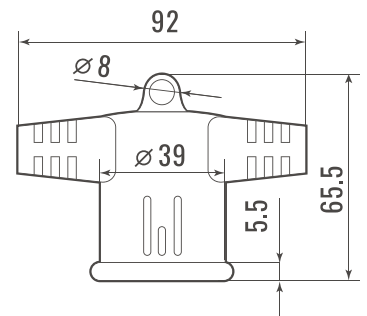

Measurements in Mm

## LIGHTING & ACCESSORIES



400 MARTIN LUTHER KING JR WAY, BRIDGETON, NJ 08302  
PHONE : (718).338.1851 FAX : (718).228.1851  
orders@ammoelectric.com

www.ammoelectric.com